

DO 160G COMPLIANT DUAL REDUNDANT 68W POWER SUPPLY MODULE

Overview

Power supply is having isolated 3 outputs with redundant power board supply and hold up capacitor.

Key Features

- 68W main and redundant power supply
- 50ms Holdup time capacitor
- Converts 14V DC to nominal DC outputs (+/- 5V DC, +/- 8V DC)
- Efficiency >85%
- Inbuilt EMI
- Dual Fan output drivers
- 2kV isolation between input and outputs

Dimension

189mm x 145.58mm x 21.65mm

Technical Specifications

- 3 Isolated outputs of 5V/6A, 8V/1.5A and 5V/1.75A.
- Current controlled Push Pull topology for isolation.
- Input requirements as per the DO-160G for 14V DC.
- Efficiency greater than 85%.
- Holdup time greater than 50ms.
- ORing input circuit for Dual aircraft input supply.
- Dual Fan driver circuit for 12V 0.6A and Fan tacho status output.
- Ripple output less than 1%.
- Line and load regulation less than 5%.
- Meeting EMI/EMC requirements as per the DO-160G.
- Input over current over voltage and under voltage protection.
- BITE outputs for monitoring health of the board.
- ROHS compliant.

Block Diagram

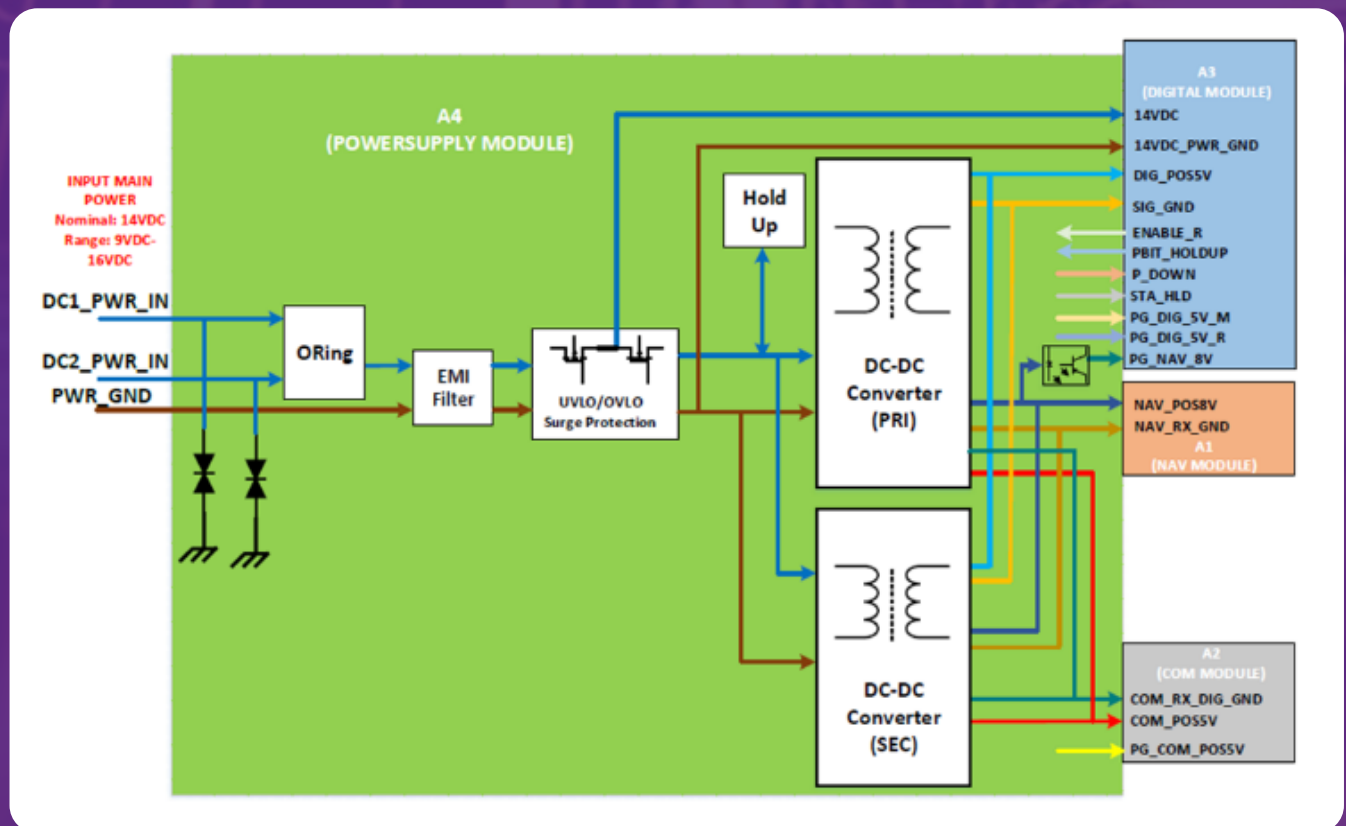

Benefits

- Overall "Low cost of ownership" to the customer due to
- Compact power supply module for aircraft application.
 - Includes the holdup capacitor inbuilt on the board.
 - Inbuilt EMI/EMC filter.

Our USP

- Triple output with good power quality
- Redundant converter with power good signals

Case Reference

- Good efficiency
- ROHS compliant

Cyient (Estd: 1991, NSE: CYIENT) is a global engineering and technology solutions company. As a design, build, operate & maintain partner for leading organizations worldwide, we take solution ownership across the value chain and leverage the power of digital technologies and advanced analytics, along with domain knowledge and technical expertise, to solve complex business problems. With more than 16,000 employees in 20 countries, our industry focus includes aerospace and defense, medical, telecommunications, rail transportation, semiconductor, industrial, and energy.